



TYPE EXAMINATION CERTIFICATE

According to Lifts Regulations 2016, Schedule 11, Section A

Certificate No.:	UK-B 159
Approved Body:	TUV SUD BABT UNLIMITED Octagon House Concorde Way, Segensworth North Fareham, Hampshire, PO15 5RL, UK Identification No. 0168
Certificate Holder:	ACLA-WERKE GMBH Frankfurter Str. 142-190 51065 Köln - Germany
Manufacturer of the Test Sample: (Manufacturer of Serial Production - see Enclosure)	ACLA-WERKE GMBH Frankfurter Str. 142-190 51065 Köln - Germany
Product:	Energy accumulation buffer with nonlinear characteristics
Type:	300400R
Regulation:	Lifts Regulations 2016
Reference Standards:	EN 81-20:2020 EN 81-50:2020
Test report:	UK-B 154-159 dated 2022-04-07
Outcome:	The product conforms to the essential health and safety requirements of the mentioned Regulation if the requirements of the annex to this type examination certificate are kept.
Date of Issue:	2022-04-07

Achim Janocha

TUV SUD BABT UNLIMITED



**Annex to the Type Examination Certificate
No. UK-B 159 of 2022-04-07**



1 Scope of application

1.1 Permissible total mass of car and rated load or counterweight by using one buffer depending on the maximum rated speeds:

Rated speed [m/s]	Min. total mass [kg]	Max. total mass [kg]
1.00	350	1700

(If several buffers are used, the permissible total mass can be multiplied accordingly.)

1.2 Further technical data / information

Maximum impact speed	1.15 m/s
Dimension	Ø 80 mm x 80 mm
Material	AUTAN XL A
Connecting elements / fixing elements / marking	see clause 2.2

1.3 Environmental conditions

Temperature	-15 °C to + 60 °C
Humidity	max. 98 % at room temperature, non-condensing
Pollution	no exposure to acids, bases, solvents

2 Conditions

- 2.1 By using more than one buffer these safety devices must be identical in design, execution and installation position.
- 2.2 The manufacturer's operating instructions must be observed in particular with regard to inspection, replacement criteria and fixing.
- 2.3 The approval drawing No. Z20014 including stamp from 2022-04-07 shall be included to the type examination for the identification and information of the general design and operation and distinctness of the approved type.
- 2.4 The type examination certificate may only be used in combination with the corresponding annex and enclosure (List of authorized manufacturers of the serial production). The enclosure will be updated immediately after any change by the certification holder.



3 Remarks

3.1 The testing of other requirements of the standard, wear-related reduction of the buffer forces, as well as permanent influence of the ambient conditions are not part of this type examination.

3.2 This type examination certificate has been issued on basis of the following standards:

- EN 81-20:2020 (D), clause 5.8.1.7
- EN 81-50:2020 (D), clause 5.5

A revision of this type examination certificate is inevitable in case of changes or additions of the above-mentioned standards or changes of state of the art.

**Enclosure to the Type Examination Certificate
No. UK-B 159 of 2022-04-07**



Authorised Manufacturer of Serial Production – Production Sites (valid from: 2021-12-21):

Company	ACLA-WERKE GMBH
Address	Frankfurter Str. 142-190 51065 Köln - Germany

- END OF DOCUMENT -

Puffertyp: 300400R1
Buffer model:
Befestigung: Typ A
Mounting types:

300400R3
Typ C

300400R4
Typ D

300400R5
Typ AD

300400R6
Typ CD

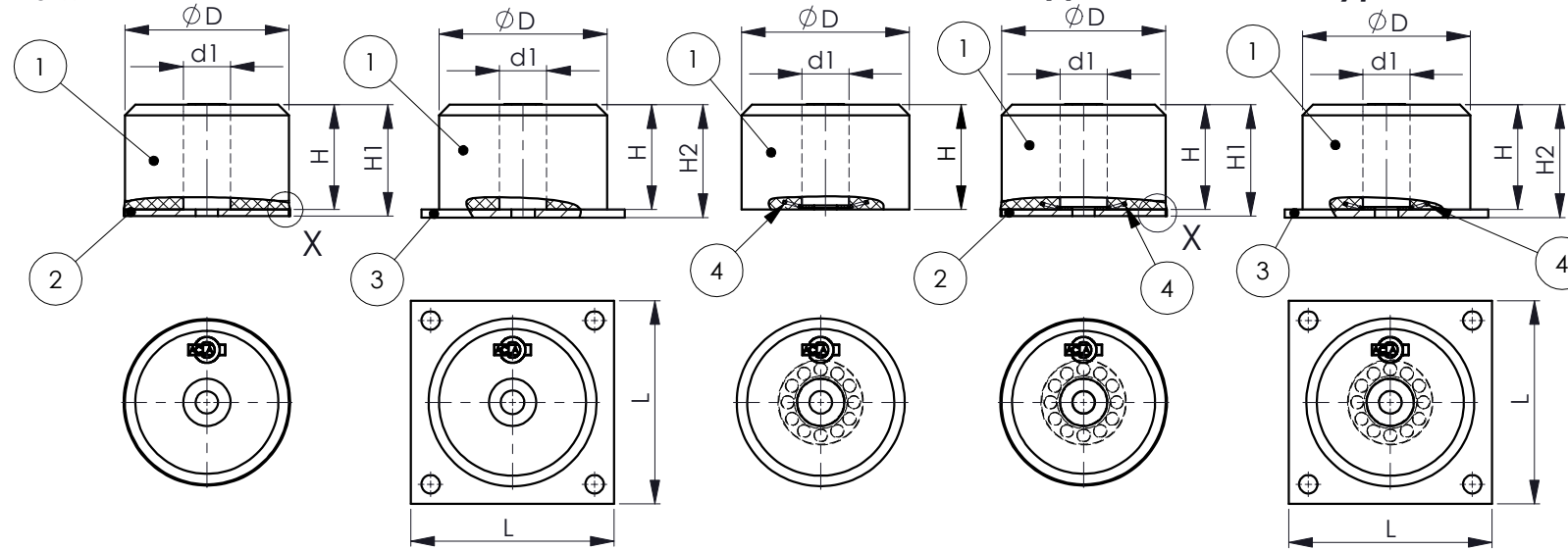

DETAIL X
Fertigungsart
 production type



Plattenkante
 Plate edge

umschäumt
 Angabe "V1"
 foams around
 specification "V1"

sichtbar
 keine Angabe
 visible
 not specified

Kennzeichnungen auf dem Puffer:

Die Kennzeichnungen können auf dem ganzen Umfang des Puffers angeordnet sein.
 Die Kennzeichnung besteht aus den Kennzeichnungsfeldern.
 (XXX Platzhalter ohne genaue Anzahl der Zeichen)
 Zusätzlich zu den beschriebenen können weitere Kennzeichnungen angebracht sein,
 zum Beispiel weitere Konformitätskennzeichnungen oder 2D-Codes.

Markings on the buffer:

The markings can be placed on the entire circumference of the buffer.
 The marking consists of the marking fields.
 (XXX placeholder without exact number of characters).
 In addition to those described, further markings may be added,
 for example further conformity markings or 2D codes

Puffertyp ----- 300XXXXX ----- Buffer model
 Datum ----- DD.MM.YYYY ----- Date
 Uhrzeit / Fertigungsart -- hh:mm:ss / V1 -- Time / Model of manufacturing
 Hersteller ----- ACLA ----- Manufacturer
 Anschrift ----- DE 51065 KOELN ----- Address



Abmessungen
 in mm

ØD	80
Ød1	36
H	80
H1	85
H2	86
L	100

07.04.2022

GEPRÜFT / APPROVED
TÜV SÜD Industrie Service GmbH

Prüfstelle Fördertechnik / Test Laboratory LCC
 Westendstr. 199, 80686 München – Germany
 Sachverständiger (m/w/d) / Expert

UK-Baumusterprüfung:

UKCA-Konformitätskennzeichen
 Nr. der zugelassene Stelle
 für die Qualitätssicherung
 Zertifikatsnummer

UK type-examination:

UKCA conformity mark
 No. of the approved body
 for quality assurance
 Certificate number

UK CA XXXX / UK-B XXX

Index	Teil	Änderungs-Mitteilung	Datum	Name

1	Lochblech / perforated sheet	4		St.
1	Platte / plate	3		St.
1	Scheibe / disc	2		St.
1	Puffer / Buffer	1		AUTAN XL A
				Werkstoff

2022	Tag	Name	300400R	ACLA-WERKE GMBH Frankfurter Str.142-190 51065 Köln
Gez.	17.01.	Kremin		
Gepr.	Überprüft Von Holger Blücher, 10.02.20.01.2023			
Norm				CAD - Zeichnung 2020
Maßstab				Z20014 Entstanden aus: Ersetzt durch:
-:-	Identifikations- Zeichnung Identification drawing			